



vito

vision on technology

17/03/2010

Een voorraadje elektrische energie bij je thuis

Grietus Mulder

Gerrit Jan Schaeffer

An energy box in each home

- » Contents
 - » Smart Grids
 - » Harmonisation methods
 - » Storage functions
 - » Domestic solutions
 - » Developments
 - » Test facilities at VITO



Smart Grids: what

- » Different paradigm from centralised grid
- » Harmonisation of demand and supply
- » With DER, RES and EV: several defies
 - » PV and wind mills are uncontrollable generation
 - » In Denmark many windmills, but no coal plant stopped
 - » Demand can explode with heat pumps and (PH)EVs
 - » The cables and transformers become too small

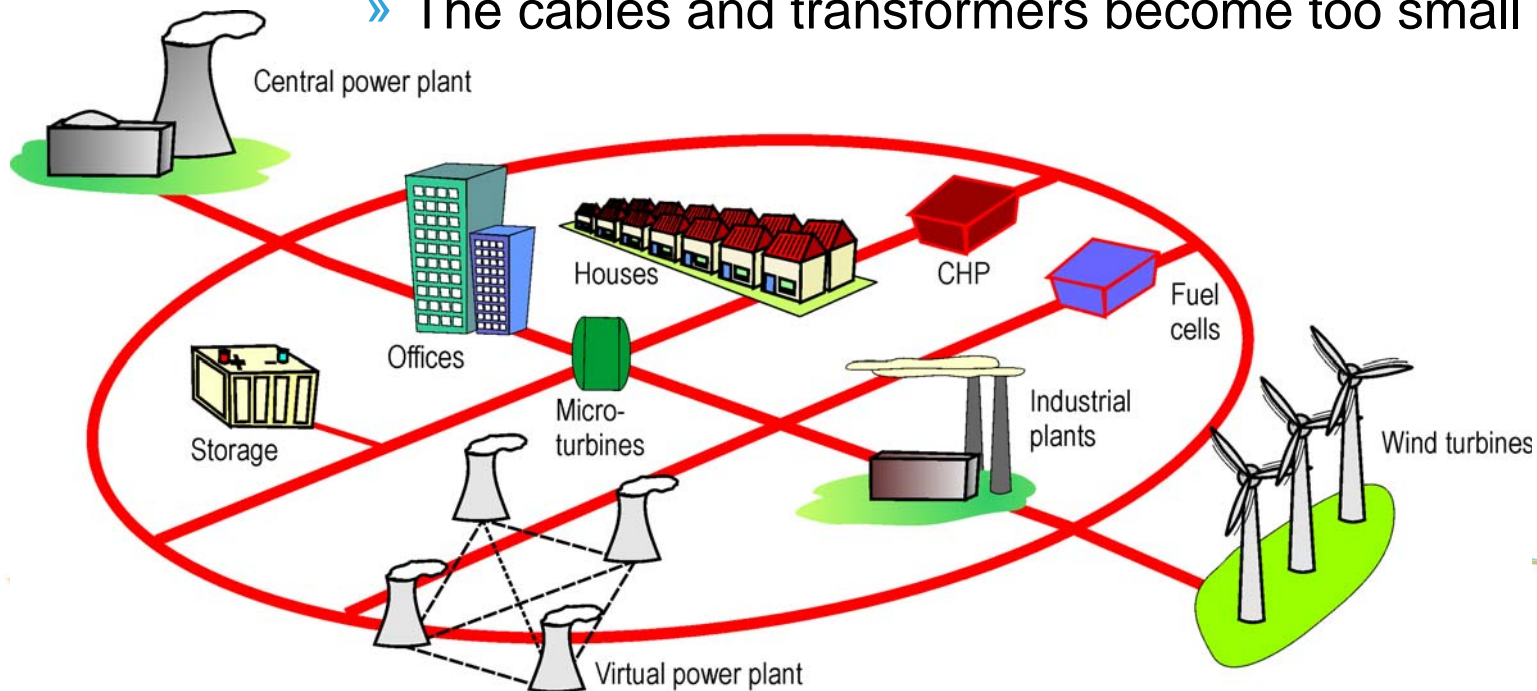

Smart Grids: how

- » Harmonisation between supply and demand
- » Two methods
 - » Harmonisation with software (scheduling)
 - » Prediction of RES production
 - » Switchable and shiftable loads
(domestic equipment, cold rooms, EVs, heat pumps)
 - » Storage
 - » Predictable RES
 - » Solving bottlenecks

Storage: functions

- » Peak shaving
- » Decrease of company's rated connection power
- » Predictable RES
- » Power back-up (UPS/ no-break)
- » Trading on the power exchange market

- » Resolving voltage bottlenecks = load shift ability
- » Reduction of line losses by transport optimisation
- » Deferment grid investments and expansions
- » Power quality

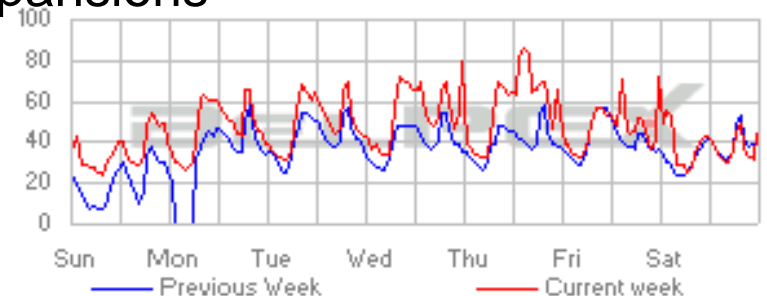

Storage: what

- » Except UPS, it is all new
- » Major drawbacks.
 - » high costs
 - » not suitable for small scale storage applications (typically for applications starting at several megawatts)
 - » the technology is still very much in an early research phase
- » However, it starts to come



Storage: legislative incentives

- » Renewable Energy Directive (2009/28/EC)
 - » Recital 57: There is a need to support the use of energy storage systems for intermittent energy production
- » Erneuerbare Energiegesetz (EEG) (Duitsland)
 - » Opslag voor hernieuwbare energie aanzien als hernieuwbare-energiefaciliteit -> prioritaire aansluiting
 - » §33.2 tarief voor lokaal eigengebruik van PV-energie



Storage: application

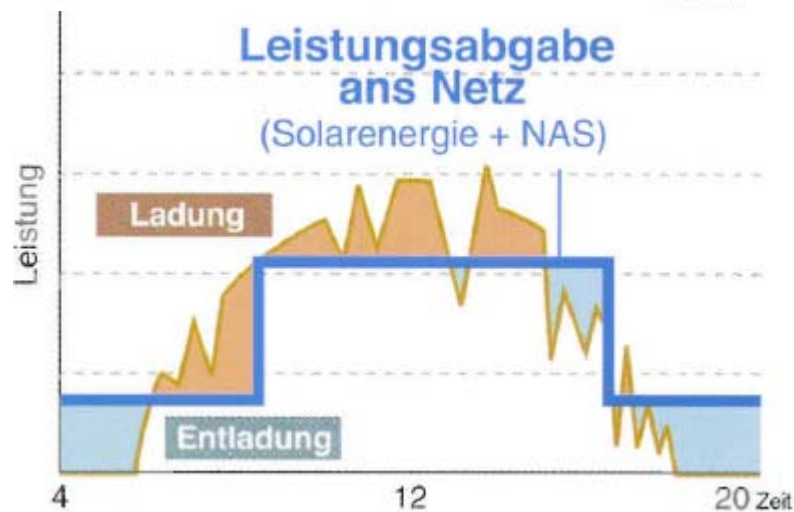
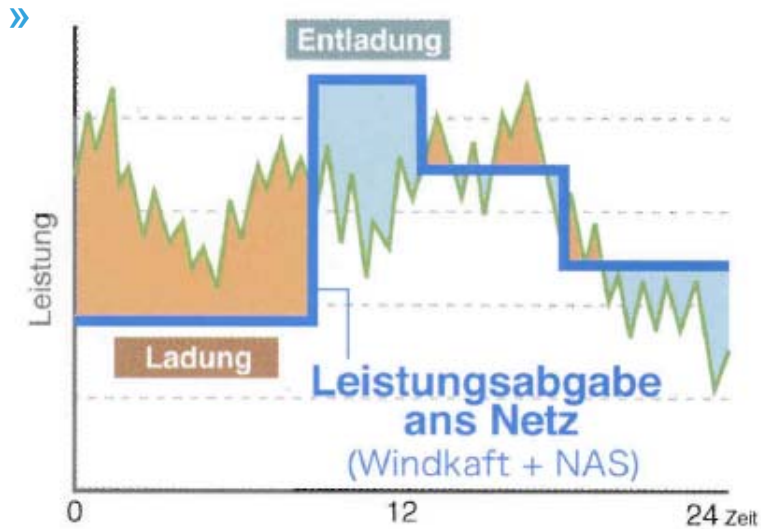

100% Nennbetrieb

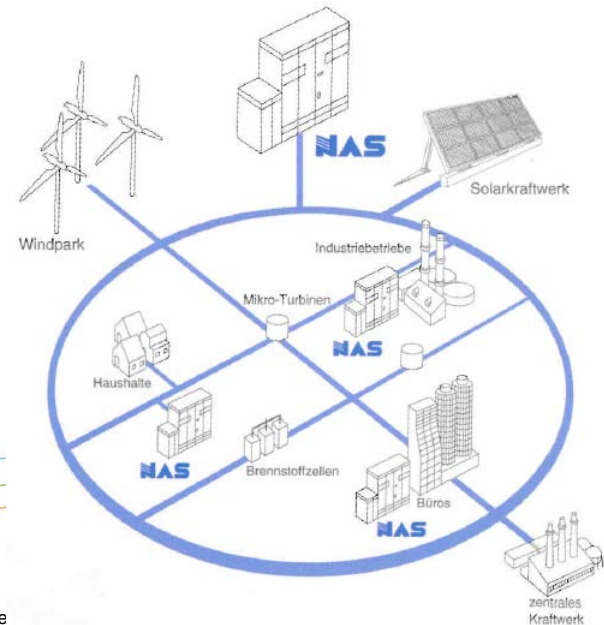
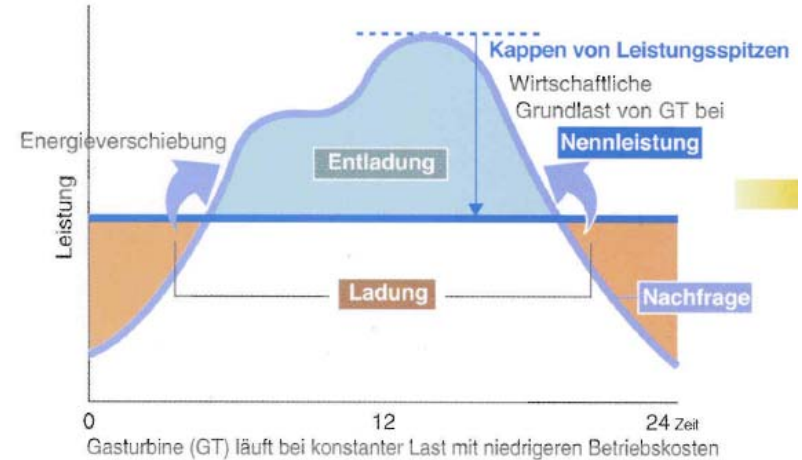

Storage

- » battery: secondary battery = rechargeable
- » Lead acid, NiCd, NiMH, Li-ion, ...
- » UPS/ no-break, peak shaving

- » PbAc: 100€/kWh
- » Li-ion: 500-1000€/kWh without system integration...

- » ±90% efficiency or 80 of 70%...

Aantal cycli ifv ΔSoC

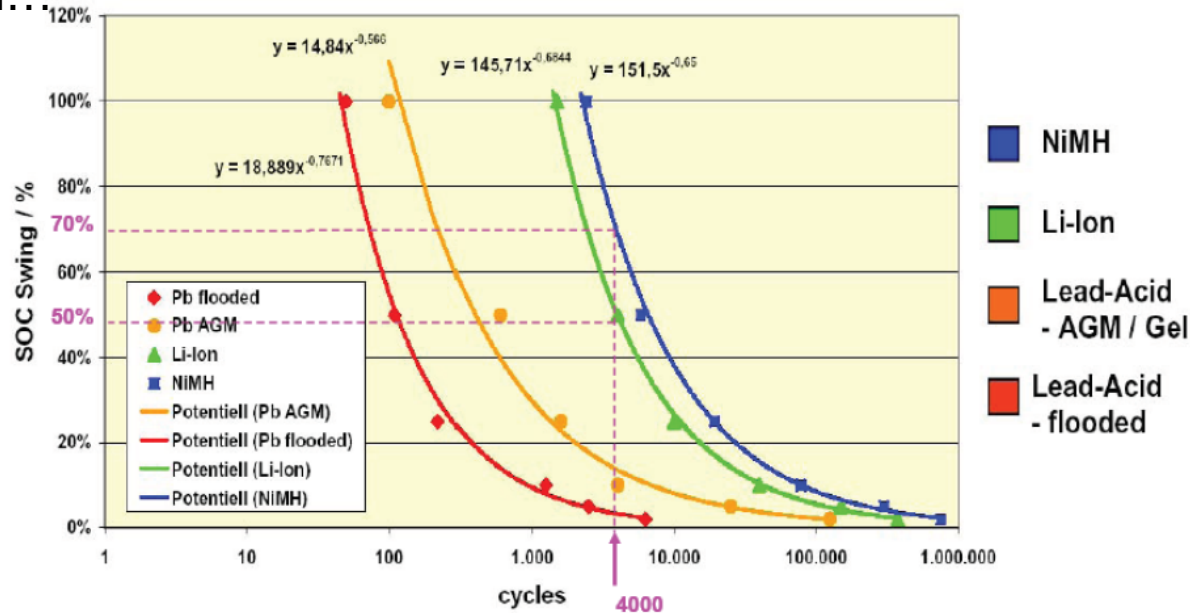

Trends in new materials development

Storage

Various cathode and anode materials for LIB are studied to further improve capacities:

- » Li-ion and Li-ion...
- » LCO
- » NCM
- » NCA
- » LFP

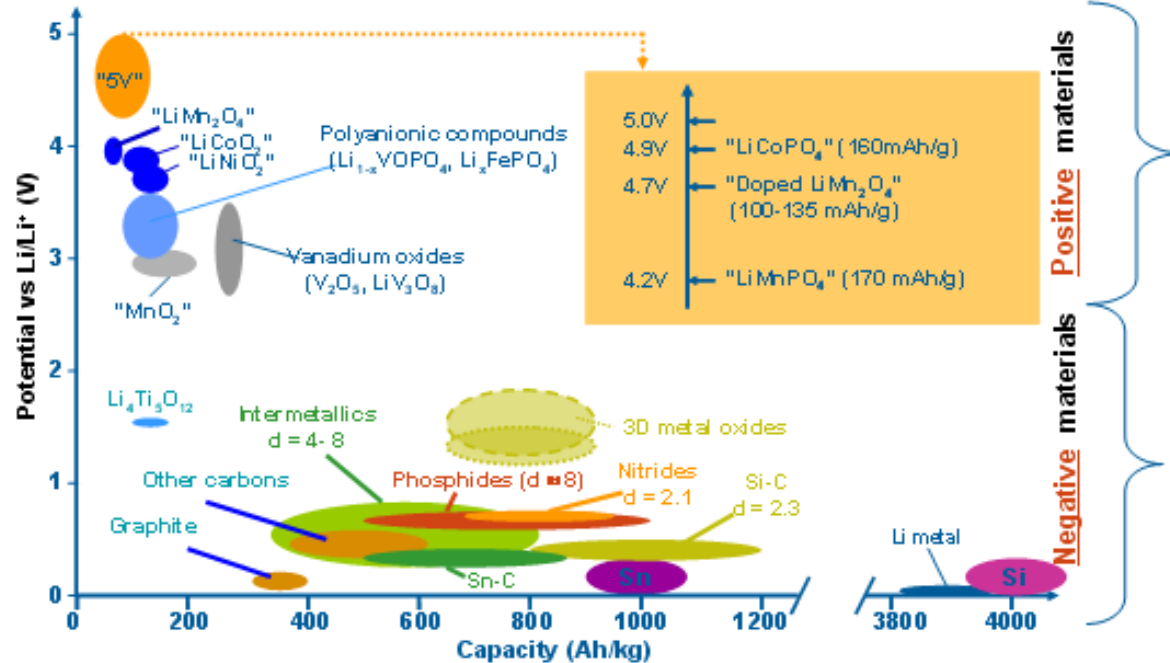

Cathodes -> more safety, higher potential, higher capacity

NANOTECHNOLOGIES

Anodes -> replacement of C by new materials with higher capacity (e.g. Sn and intermetallics)

Storage for households

- » In house (lead acid, NiMH, Li-ion)
- » Or integrated in PV panel (LiFePO₄)

Photo under way

Storage for households

- » In house (lead acid, NiMH, Li-ion)

Fumio Otsubo, president of Panasonic:
“We’ll be the first to bring to the market a storage battery for home use, which can store sufficient electricity for about one week of use”

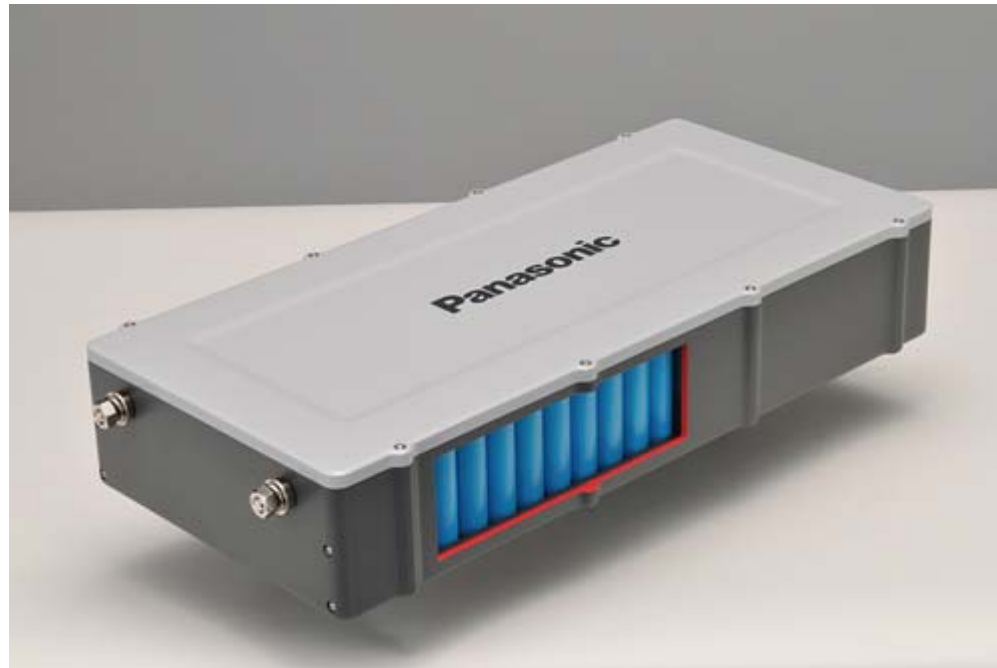

Storage for households



Yunicos konzipiert und vertreibt neuartige Versorgungskonzepte auf Basis erneuerbarer Energien, von Kleinstsystemen bis komplexen Netz- strukturen.



E-Shuttle



Storage for households

- » SMA Sunny Island
 - » Storage in island use
 - » or as UPS in grid use

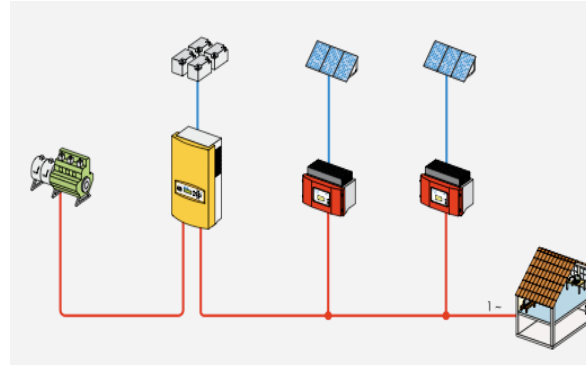

Storage for households

PowerRouter, 5kW hybrid inverter

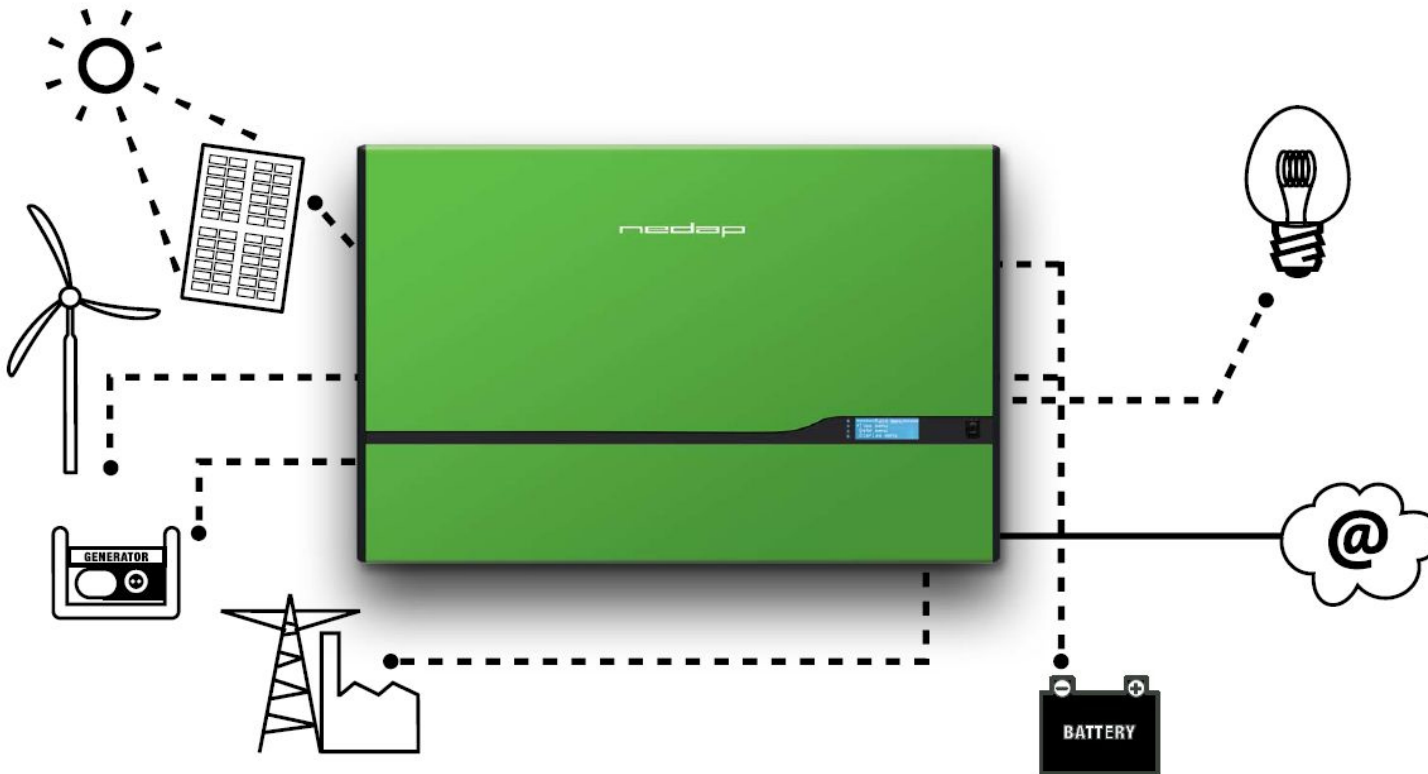

Cost reductions PV

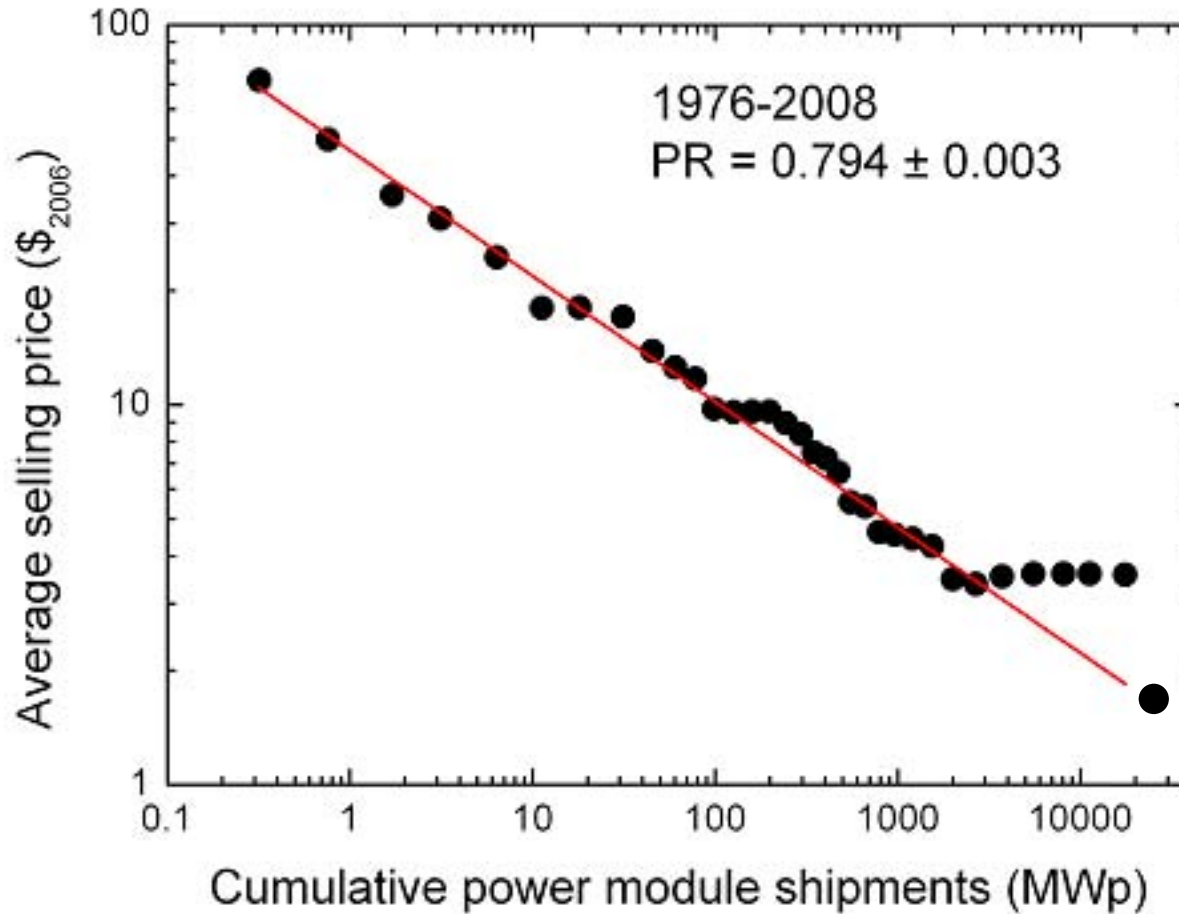

2009

Cost leader
First Solar
Below 1 \$/W

Storage for households

- » PV installation prices drop fast
- » It can become 1,25€/Wpeak (5-10 years)
 - » Consisting of 0,5€ for PV module, 0,5€ for installation (not decreasing) and 0,25€ for inverter
 - » 2kW –installation: 2500€
- » Batteries become cheaper
 - » Li-ion: 200€/kWh
 - » 3kWh battery : 600€
2kW inverter: 500€
- » Costs and prices...

Development for Power Quality

- » Clouds change drastically the PV power output
- » Power line voltage changes either (flicker)
- » Ultracaps to resolve this

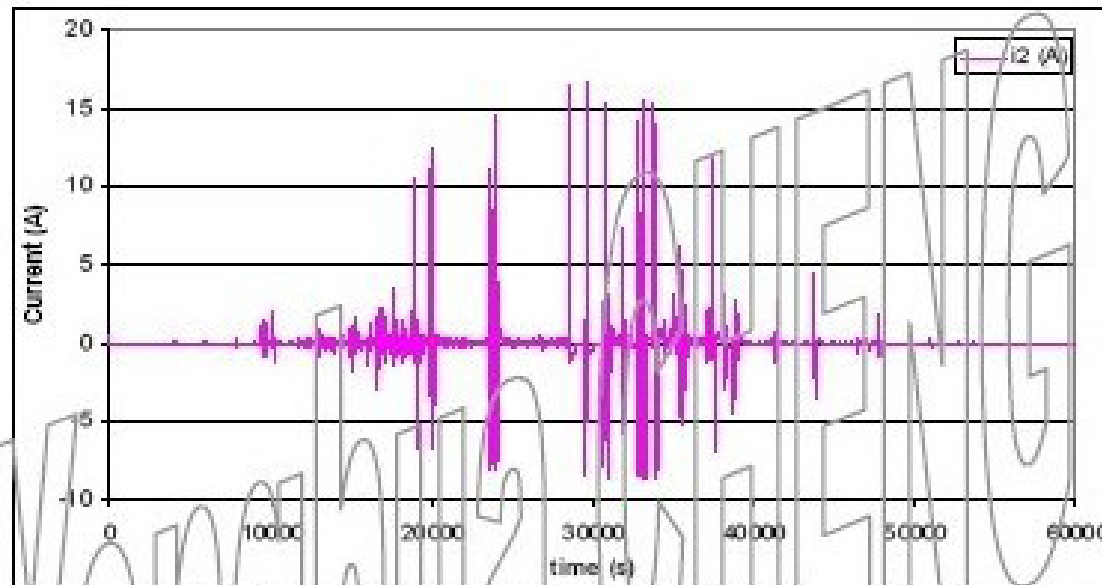
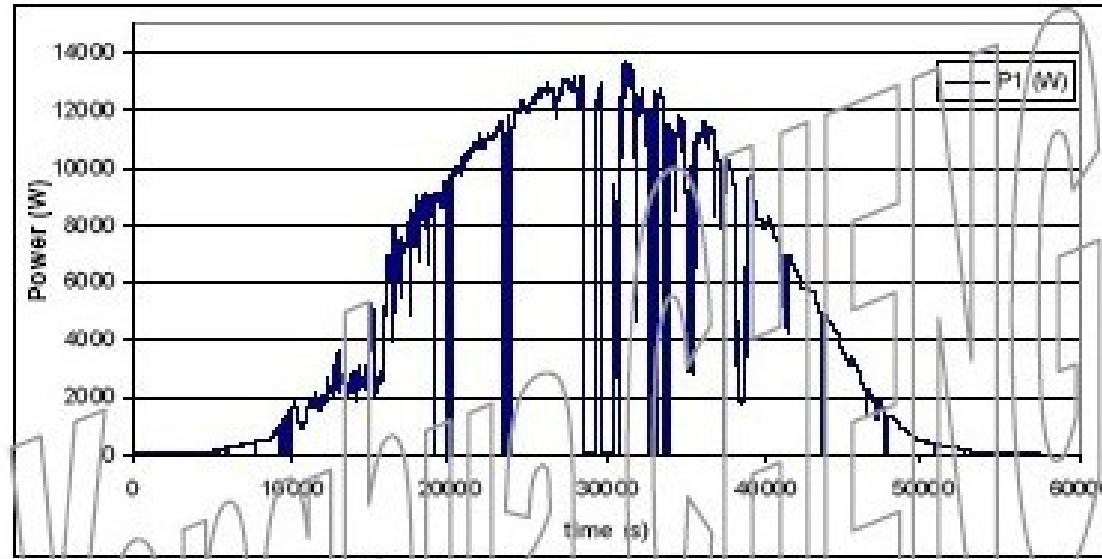

Development for households

- » Voltage bottleneck
- » Own consumption
- » Predictable PV output
- » Predictable demand / peak shaving
- » Trading

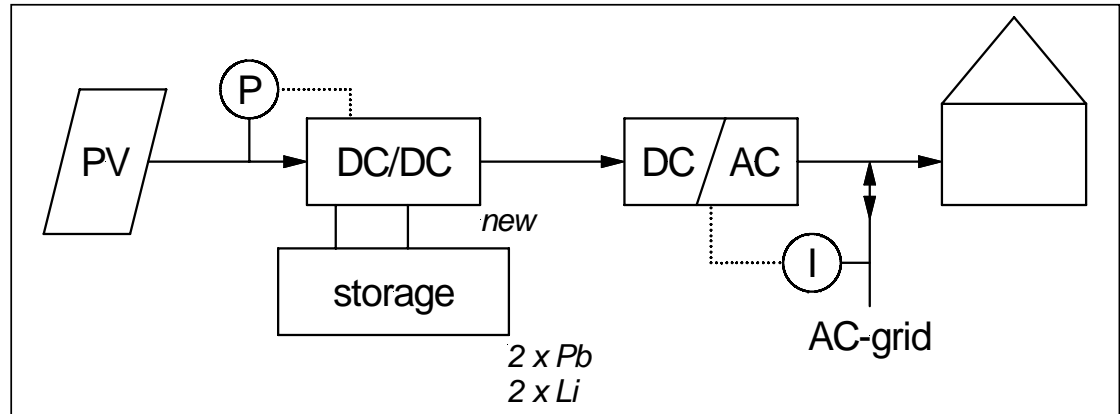

Monthly production and consumption

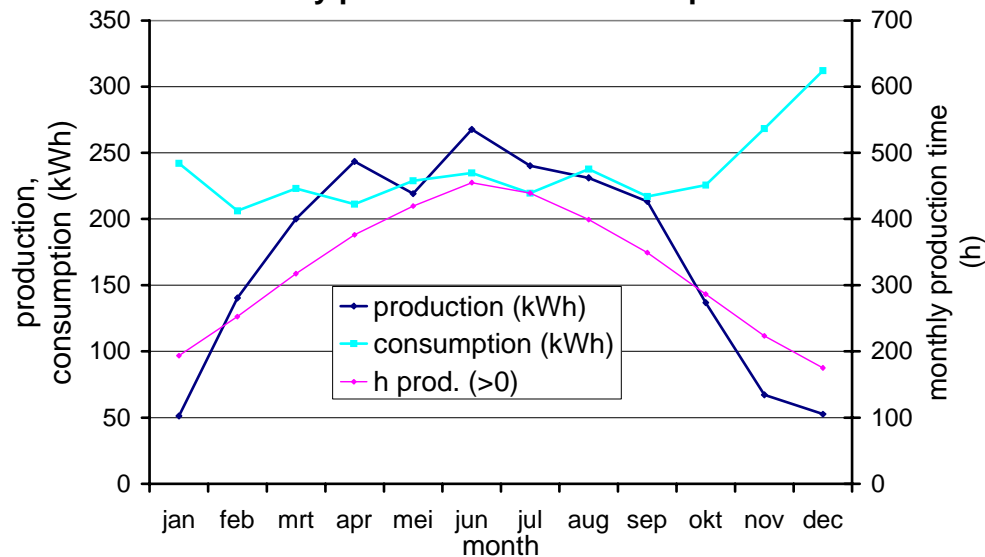

Relation between electricity towards grid and optimised storage size

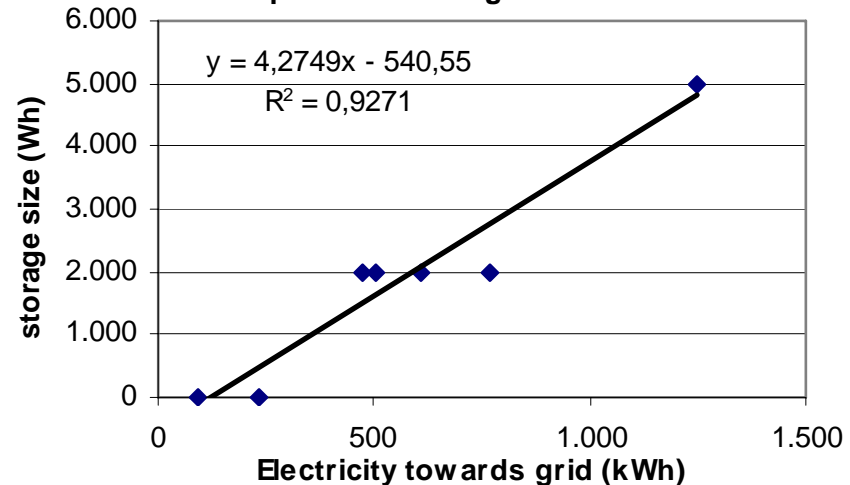

An energy box in each home

- » Contents
 - » Smart Grids
 - » Harmonisation methods
 - » Storage functions
 - » Domestic solutions
 - » Developments
 - » Test facilities at VITO



Storage tests at VITO

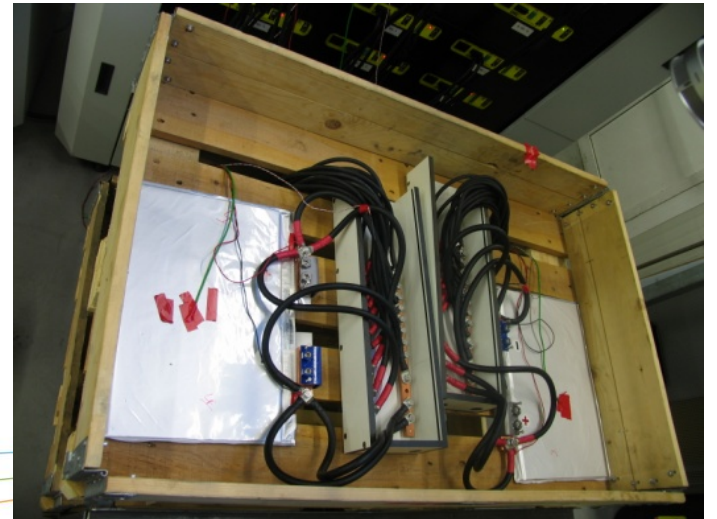
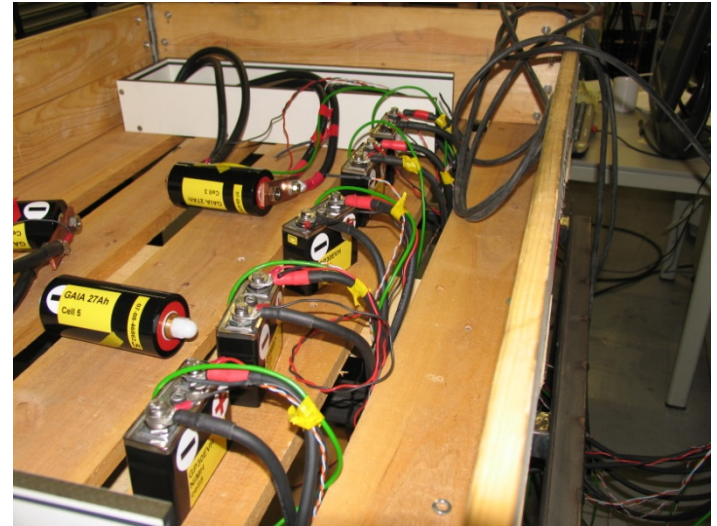

Test Infrastructure → Electro technical laboratory hybrid & electric drive trains Thermo technical laboratory Fuel cell laboratory Battery laboratory

